

India's Only Butterfly Valve built with Reinforced Polypropylene

Ravands butterfly poses all the DNA features of a Ravands product. Best in class material, Unmatched design features and Robust performance in field.

Proudly made in India, the Ravands butterfly valve is based on a simple on/off action and is easy and quick to install allowing the user Complete control of water distribution. It's a Butterfly Valve that meets harsh and unpredictable field requirements



Ravands Control LLP
Puthalapattu
Chittoor - 517124
A.P. INDIA.
Mail: sales@ravands.com

For Enquires
Ph: +91-995-979-9292
www.ravands.com



(RAVANDS)

India's Only PPGF Butterfly Valve Master of Flow Control



(RAVANDS)

You can rest easy when you install Ravands Butterfly Valve

- **Install in Any Direction**
- **Every Valve is Pressure Tested**
- **UV Stabilized Materials**
- **Frost Resistant**
- **Robust and light weight**
- **Unparalleled reliability**
- **Indian Made**
- **5 year Warranty**

(RAVANDS)

Advantages

Positive Positioning of Disc:
Intermittent locking provision for positive positioning of disc

Versatile installation:
Oval holes to fit with different flange standards

No additional flange required:
Full body liner seat support avoids flange gaskets

Extension handle:
For deep pipeline applications, handle with extension rod for easy operation.

Strong Body:
Robust body built with glass reinforced Polypropylene material



Features

PRINCIPALS OF OPERATION : BUTTERFLY VALVE

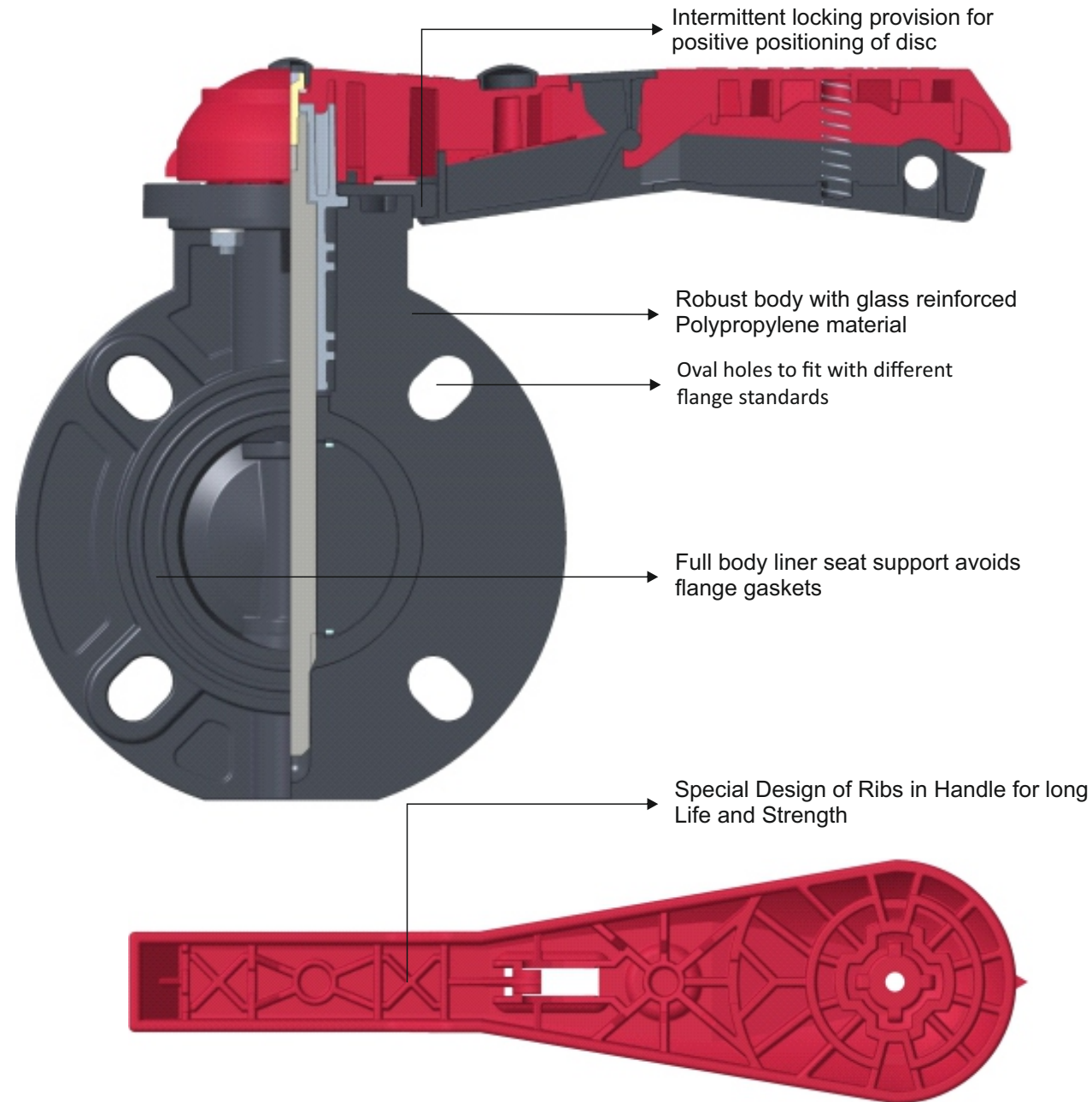

EASY INSTALLATION

FOR Flanged JOINTS

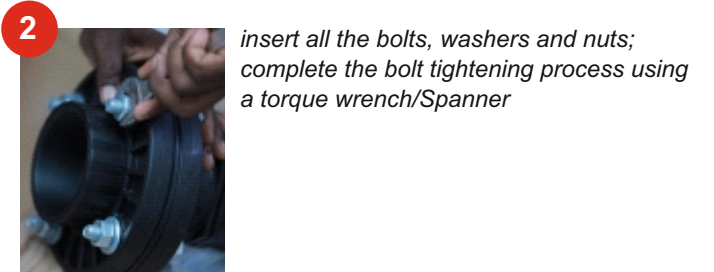
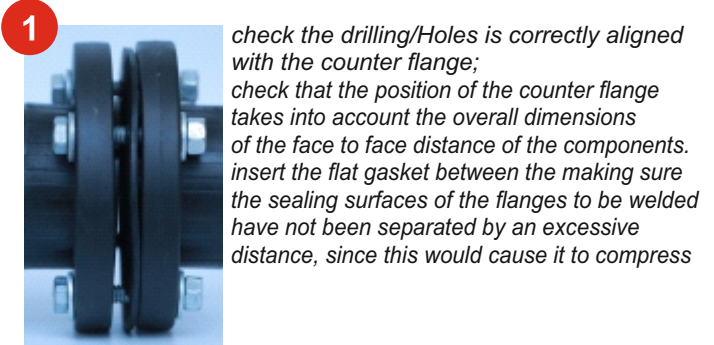

Ravands Butterfly Valves are available in Sizes 2" , 2.5" & 3"

